

SC 402107
WASSCE 2025
GENERAL MATHEMATICS/
MATHEMATICS (CORE) 1
Objective Test
 1½ hours

Name

Index Number

- ❖ TOPIC BASE, MOCK & PAST QUESTIONS
- ❖ NOTES
- ❖ SYLLABUS
- ❖ CHIEF EXAMINERS' REPORT
- ❖ LESSON NOTES
- ❖ COURSES
- ❖ CAREER/SCHOLARSHIP OPPORTUNITIES
- ❖ CAMPUS NEWS

THE WEST AFRICAN EXAMINATIONS

**West African Senior School Certificate Examination
 for School Candidates**

SC 2025

GENERAL MATHEMATICS/ MATHEMATICS(CORE) 1

1½ hours

OBJECTIVE TEST

[50 marks]

Do not open this booklet until you are told to do so. While you are waiting, read and observe the following instructions. Write your name and index number in the spaces provided above.

1. Use **2B** pencil throughout.
2. On the pre-printed answer sheet, check that the following details are **correctly** printed:
 - (a) In the space marked *Name*, check your **surname** followed by your **other names**.
 - (b) In the spaces marked *Examination, Year, Subject* and *Paper*, write 'WASSCE(SC)'2025', 'GENERAL MATHEMATICS/MATHEMATICS (CORE)', and '1' respectively.
 - (c) In the box marked *Index Number*; your **index number** has been printed vertically in the spaces on the left-hand side, and each numbered space has been shaded in line with each digit. **Reshade** each of the shaded spaces.
 - (d) In the box marked *Subject Code*, the digits 402112 are printed vertically in the spaces on the left-hand side. **Reshade** the corresponding numbered spaces as you did for your index number.
3. An example is given below. This is for a male candidate whose *name* is Ben Abu TETTEH. His *index number* is 7102143958 and he is offering *Mathematics (Core) 1*.

THE WEST AFRICAN EXAMINATIONS COUNCIL
ANSWER SHEET

PRINT IN BLOCK LETTERS	
Name: TETTEH BEN ABU	GHA
Examination: WASSCE SC	Year: 2025
Subject: MATHS(CORE)	Paper: 1

INSTRUCTIONS TO CANDIDATES

1. Use grade 2B pencil throughout.
2. Answer each question by choosing one letter and shading like this: A B C D
3. Erase completely any answer you wish to change.
4. Leave extra spaces blank if the answer spaces provided are more than you need.
5. Do not make any markings across the heavy black marks at the right hand edge of your answer sheet.

INDEX NUMBER	SUBJECT CODE
7 <input type="radio"/> 0 <input type="radio"/> 1 <input type="radio"/> 2 <input type="radio"/> 3 <input type="radio"/> 4 <input type="radio"/> 5 <input type="radio"/> 6 <input type="radio"/> 7 <input type="radio"/> 8 <input type="radio"/> 9	4 <input type="radio"/> 0 <input type="radio"/> 1 <input type="radio"/> 2 <input type="radio"/> 3 <input type="radio"/> 4 <input type="radio"/> 5 <input type="radio"/> 6 <input type="radio"/> 7 <input type="radio"/> 8 <input type="radio"/> 9
1 <input type="radio"/> 0 <input type="radio"/> 1 <input type="radio"/> 2 <input type="radio"/> 3 <input type="radio"/> 4 <input type="radio"/> 5 <input type="radio"/> 6 <input type="radio"/> 7 <input type="radio"/> 8 <input type="radio"/> 9	0 <input type="radio"/> 0 <input type="radio"/> 1 <input type="radio"/> 2 <input type="radio"/> 3 <input type="radio"/> 4 <input type="radio"/> 5 <input type="radio"/> 6 <input type="radio"/> 7 <input type="radio"/> 8 <input type="radio"/> 9
0 <input type="radio"/> 0 <input type="radio"/> 1 <input type="radio"/> 2 <input type="radio"/> 3 <input type="radio"/> 4 <input type="radio"/> 5 <input type="radio"/> 6 <input type="radio"/> 7 <input type="radio"/> 8 <input type="radio"/> 9	2 <input type="radio"/> 0 <input type="radio"/> 1 <input type="radio"/> 2 <input type="radio"/> 3 <input type="radio"/> 4 <input type="radio"/> 5 <input type="radio"/> 6 <input type="radio"/> 7 <input type="radio"/> 8 <input type="radio"/> 9
2 <input type="radio"/> 0 <input type="radio"/> 1 <input type="radio"/> 2 <input type="radio"/> 3 <input type="radio"/> 4 <input type="radio"/> 5 <input type="radio"/> 6 <input type="radio"/> 7 <input type="radio"/> 8 <input type="radio"/> 9	1 <input type="radio"/> 0 <input type="radio"/> 1 <input type="radio"/> 2 <input type="radio"/> 3 <input type="radio"/> 4 <input type="radio"/> 5 <input type="radio"/> 6 <input type="radio"/> 7 <input type="radio"/> 8 <input type="radio"/> 9
1 <input type="radio"/> 0 <input type="radio"/> 1 <input type="radio"/> 2 <input type="radio"/> 3 <input type="radio"/> 4 <input type="radio"/> 5 <input type="radio"/> 6 <input type="radio"/> 7 <input type="radio"/> 8 <input type="radio"/> 9	1 <input type="radio"/> 0 <input type="radio"/> 1 <input type="radio"/> 2 <input type="radio"/> 3 <input type="radio"/> 4 <input type="radio"/> 5 <input type="radio"/> 6 <input type="radio"/> 7 <input type="radio"/> 8 <input type="radio"/> 9
4 <input type="radio"/> 0 <input type="radio"/> 1 <input type="radio"/> 2 <input type="radio"/> 3 <input type="radio"/> 4 <input type="radio"/> 5 <input type="radio"/> 6 <input type="radio"/> 7 <input type="radio"/> 8 <input type="radio"/> 9	2 <input type="radio"/> 0 <input type="radio"/> 1 <input type="radio"/> 2 <input type="radio"/> 3 <input type="radio"/> 4 <input type="radio"/> 5 <input type="radio"/> 6 <input type="radio"/> 7 <input type="radio"/> 8 <input type="radio"/> 9
3 <input type="radio"/> 0 <input type="radio"/> 1 <input type="radio"/> 2 <input type="radio"/> 3 <input type="radio"/> 4 <input type="radio"/> 5 <input type="radio"/> 6 <input type="radio"/> 7 <input type="radio"/> 8 <input type="radio"/> 9	
9 <input type="radio"/> 0 <input type="radio"/> 1 <input type="radio"/> 2 <input type="radio"/> 3 <input type="radio"/> 4 <input type="radio"/> 5 <input type="radio"/> 6 <input type="radio"/> 7 <input type="radio"/> 8 <input type="radio"/> 9	
5 <input type="radio"/> 0 <input type="radio"/> 1 <input type="radio"/> 2 <input type="radio"/> 3 <input type="radio"/> 4 <input type="radio"/> 5 <input type="radio"/> 6 <input type="radio"/> 7 <input type="radio"/> 8 <input type="radio"/> 9	
8 <input type="radio"/> 0 <input type="radio"/> 1 <input type="radio"/> 2 <input type="radio"/> 3 <input type="radio"/> 4 <input type="radio"/> 5 <input type="radio"/> 6 <input type="radio"/> 7 <input type="radio"/> 8 <input type="radio"/> 9	

For Supervisors only

If candidate is absent shade this space

Answer **all** the questions.

Mathematical tables may be used in **any** question. The use of non-programmable, silent and cordless calculator is allowed.

Each question is followed by **four** options lettered A to D. Find the **correct** option for **each** question and shade in **pencil**, on your answer sheet, the answer space which bears the same letter as the option you have chosen.

Give only **one** answer to **each** question. An example is given below.

The ages, in years, of four boys are 10, 12, 14 and 18. What is the average age of the boys?

- A. 12 years
- B. $13\frac{1}{2}$ years
- C. 13 years
- D. $12\frac{1}{2}$ years

The correct answer is $13\frac{1}{2}$ years, which is lettered B, and therefore answer space B would be shaded.

A B C D

Think carefully before you shade the answer spaces; erase completely any answers you wish to change.

Do all rough work on this question paper.

Now answer the following questions.

1. Given that $\log_{10} 5 = x$ and $\log_{10} 11 = y$, express $\log_{10} 275$ in terms of x and y .
 - A. $2x + y$
 - B. $2(x + y)$
 - C. $x + 2y$
 - D. $2xy$

2. The sets $P = \{x: x = 3, 5, 6\}$ and $Q = \{x: 2 \leq x \leq 5\}$ are subsets of $\mu = \{x: 1 \leq x \leq 10, \text{ where } x \text{ is an integer}\}$. Find $P' \cap Q$.
 - A. $\{2, 4\}$
 - B. $\{1, 4\}$
 - C. $\{4, 5\}$
 - D. $\{3, 4\}$

3. A pyramid has a rectangular base of length 6.5 cm and width 4.2 cm. If the height of the pyramid is 12 cm, find the volume.
 - A. 32.70 cm^3
 - B. 109.2 cm^3
 - C. 10.20 cm^3
 - D. 327.6 cm^3

4. Given that $\left(1\frac{2}{3}\right)^x = \left(4\frac{17}{27}\right)$, find the value of x .
- A. 3
B. 2
C. 5
D. 6
5. The first 4 terms of an Arithmetic Progression (A.P) are 8, x , y and 17. Find the value of $(x + y)$.
- A. 25
B. 20
C. 31
D. 40
6. In a test, the mean mark of 25 students in a class, P , is 72.2 and the mean mark of 20 students in another class, Q , is 65. Find the mean mark of all the students in P and Q .
- A. 69
B. 70
C. 68
D. 66
7. Mr. Gyan bought a car for \$16,800.00 and later sold it at 85 % of the original cost. He spent \$3,930.75 from the money he received from the sale of the car and invested the remaining at 18 % per annum simple interest. How much interest did he earn in 9 years?
- A. \$32,018.32
B. \$67,657.00
C. \$20,848.19
D. \$16,765.79
8. The mean and range of 1.20, 1.00, 0.90, 1.40, 0.80, 0.80, 1.20 and 1.10 are m and r respectively. Find the value of $(m + r)$
- A. 2.45
B. 2.55
C. 1.85
D. 1.65
9. Given that $\frac{3}{x+y} - \frac{4}{x-y} = 0$, find the value of $\frac{x}{y}$, where $y \neq 0$.
- A. -7
B. 7
C. $-\frac{1}{7}$
D. $\frac{1}{7}$

10. The last term of the sequence: 7, 11, 15, ... is 115. Find the number of terms in the sequence.
- 28
 - 29
 - 27
 - 26
11. Find the mean deviation of 2, 5, 7, 9 and 15.
- 3.52
 - 2.45
 - 4.14
 - 5.23
12. The locus, L is such that $|PM| = |PN|$. Which of the following best describes L ?
- It is the locus of points parallel to line MN .
 - It is the locus of points perpendicular to the line MN .
 - It is the locus of points equidistant from M and N .
 - It is the circle centre P , radius MN .
13. A train is moving at 60 miles per hour. If it passes a sign post in 15 seconds, find, in yards, the length of the train. [Take 1 mile = 1760 yards]
- 420 yards
 - 440 yards
 - 400 yards
 - 360 yards
14. Kwaku is 2 years older than Atanga and 6 years younger than Esi. The sum of their ages is 70. If they decide to share \$153.00 in the ratio of their ages, how much will the eldest person receive?
- \$51.00
 - \$61.20
 - \$48.09
 - \$43.71
15. Solve: $\frac{\log_3(2x - 1)}{\log_3 243} = \frac{2}{5}$
- $x = 4$
 - $x = 3$
 - $x = 5$
 - $x = 6$
16. The sum of the ages of Esi and Amina is 24 years and the difference in their ages is 6 years. If Amina is older than Esi, find Esi's age.
- 12
 - 9
 - 13
 - 15

17. Solve: $4x + 1 = 3 \pmod{11}$.

- A. 4
 B. 3
 C. 5
 D. 6

18.

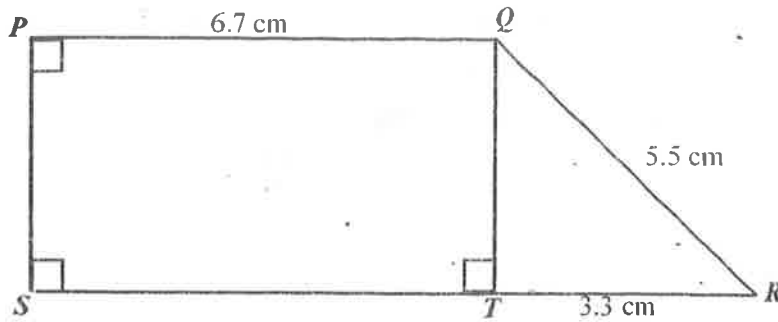

NOT DRAWN TO SCALE

In the diagram, $|PQ| = 6.7$ cm, $|QR| = 5.5$ cm and $|RT| = 3.3$ cm. Find the area.

- A. 36.74 cm^2
 B. 45.93 cm^2
 C. 27.56 cm^2
 D. 26.40 cm^2

19.

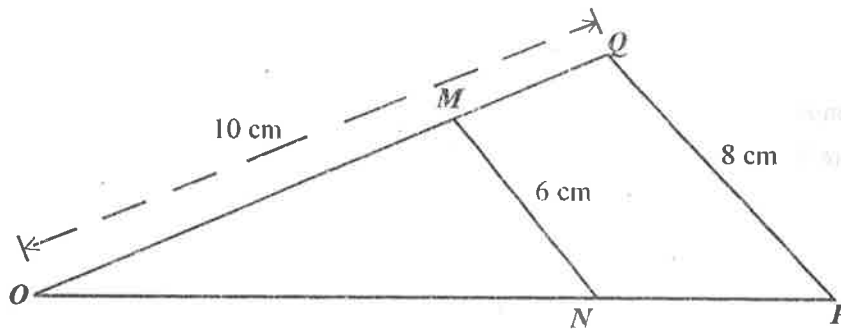

NOT DRAWN TO SCALE

In the diagram, $\triangle OMN$ is similar to $\triangle OPQ$. Find $|MQ|$.

- A. 3.5 cm
 B. 4.0 cm
 C. 3.0 cm
 D. 2.5 cm

20.

A scientific sensor records air pollution levels in base 3. If the highest recorded pollution level for a week was 2120_3 , what is the decimal equivalent?

- A. 65
 B. 62
 C. 69
 D. 72

21. Factorize: $5p^2 + 4pq - 15pr - 12qr$.

- A. $(p + 3r)(5p + 4q)$
- B. $(p - 3r)(5p + 4q)$
- C. $(p + 3r)(5p - 4q)$
- D. $(p - 3r)(5p - 4q)$

22. A school has a total population of 1,800 students. Out of this number $\frac{4}{9}$ are in SHS 1, $\frac{13}{36}$ are in SHS 2 and the rest are in SHS 3. Calculate the number of students in SHS 3.

- A. 650
- B. 800
- C. 500
- D. 350

23. The straight line $3y + bx - 6 = 0$ passes through (3, 4). Find the value of b .

- A. 8
- B. 12
- C. -2
- D. -8

24. A function is defined by $g: x \rightarrow \frac{2x-1}{3x-2}$. For what value of x is g not defined?

- A. $-\frac{2}{3}$
- B. $\frac{2}{3}$
- C. $\frac{1}{2}$
- D. $-\frac{1}{2}$

25.

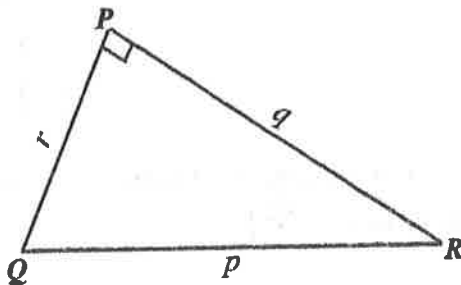

NOT DRAWN TO SCALE

In the diagram $\angle QPR = 90^\circ$. If $q^2 = 25 - r^2$, find the value of p .

- A. 5
- B. 4
- C. 3
- D. 6

26.

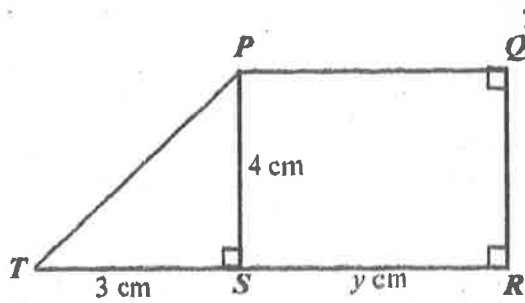

NOT DRAWN TO SCALE

In the diagram $PQRST$ is a trapezium. $|ST| = 3$ cm, $|RS| = y$ cm and $|PS| = 4$ cm.

For what values of y will the area of the trapezium $PQRST$ be less than or equal to 10 cm²?

- A. $y \leq 1$ cm
 B. $y \leq 4$ cm
 C. $y \leq 2$ cm
 D. $y \leq 6$ cm
27. A town P is due south of town Q and town R is on a bearing of 125° from Q . If town R is 20 km due east of P , find $|PQ|$.
- A. 15 km
 B. 20 km
 C. 14 km
 D. 12 km

28.

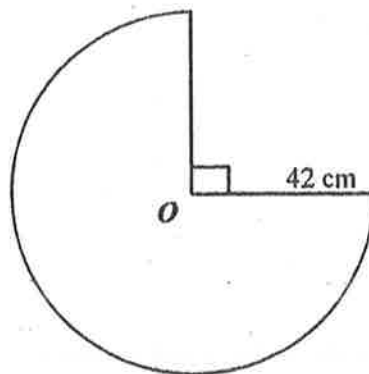

NOT DRAWN TO SCALE

The diagram shows a sector of a circle of radius 42 cm. If the sector is folded to form a right circular cone, find the surface area of the cone. [Take $\pi = \frac{22}{7}$]

- A. $5,544$ cm²
 B. $4,158$ cm²
 C. $11,088$ cm²
 D. $29,106$ cm²

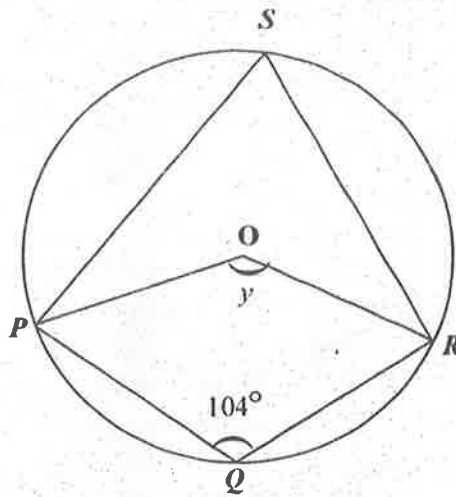

NOT DRAWN TO SCALE

In the diagram, P, Q, R and S are points on the circle centre O and $\angle PQR = 104^\circ$. Find the angle marked y .

- A. 76°
- B. 152°
- C. 52°
- D. 208°

30.

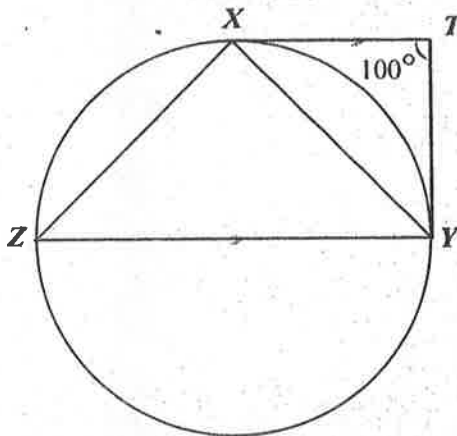

NOT DRAWN TO SCALE

In the diagram \overline{TX} and \overline{TY} are tangents to the circle XYZ at X and Y respectively. $\overline{TX} \parallel \overline{YZ}$ and $\angle XTY = 100^\circ$. Find $\angle ZXY$.

- A. 100°
- B. 130°
- C. 90°
- D. 80°

31. The radius of a circle is 4 times the radius of another circle. What is the relationship between their areas?

- A. The area of one is 16 times that of the other.
- B. The area of one is 64 times that of the other.
- C. The area of one is 12 times that of the other.
- D. The area of one is 8 times that of the other.

32.

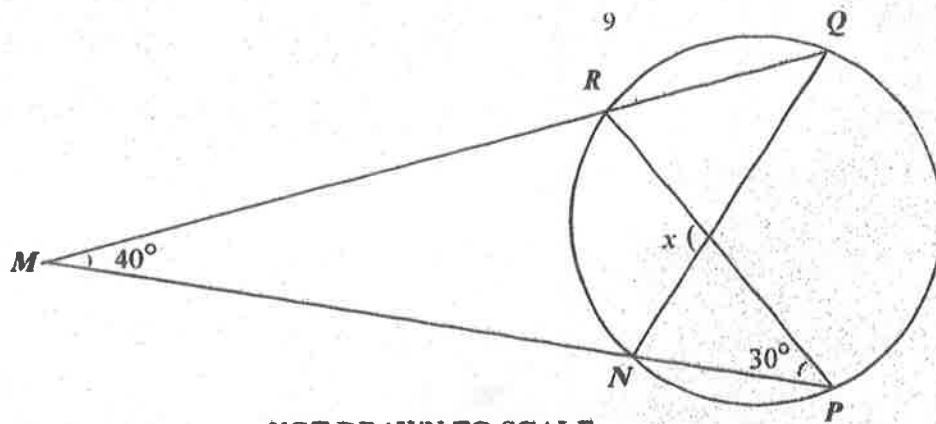

NOT DRAWN TO SCALE

In the diagram, $\angle QMP = 40^\circ$ and $\angle RPM = 30^\circ$. Find the value of x .

- A. 70°
- B. 40°
- C. 100°
- D. 110°

33.

Some of the interior angles of a pentagon are 111° , 131° and 79° . The remaining angles are x and y in the ratio 2 : 3 respectively. Find, correct to the nearest whole number, the value of x .

- A. 56°
- B. 44°
- C. 80°
- D. 88°

34.

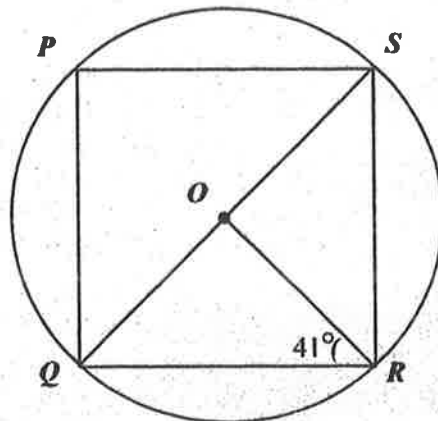

NOT DRAWN TO SCALE

In the diagram, P , Q , R and S are points on the circle centre O . \overline{PS} is a diameter and $\angle ORQ = 41^\circ$. Find $\angle QSR$.

- A. 49°
- B. 41°
- C. 60°
- D. 82°

35.

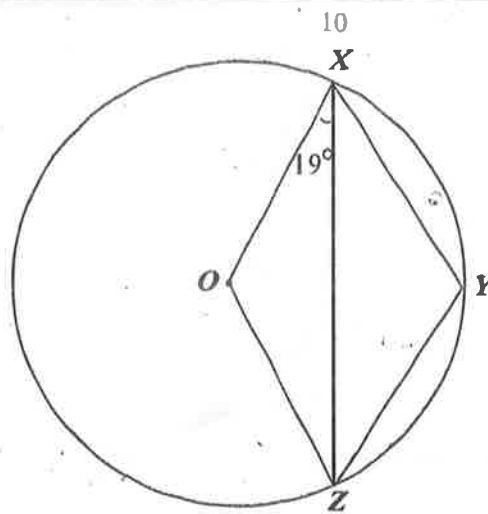

NOT DRAWN TO SCALE

In the diagram, O is the centre of the circle and $\angle OXZ = 19^\circ$. Find $\angle XYZ$.

- A. 109°
 B. 142°
 C. 71°
 D. 68°
36. A car consumes 36 gallons of fuel over a distance of 2,268 km. Find, in km per litre, the fuel consumption. [Take 1 gallon = 4.5 litres]
- A. 15
 B. 14
 C. 50
 D. 63
37. Make w the subject of the relation $\frac{1}{w} = (h-1)\left(\frac{1}{m} - \frac{1}{n}\right)$.
- A. $w = \frac{mn}{(h-n)(1-m)}$
 B. $w = \frac{mn}{(h-1)(n-m)}$
 C. $w = \frac{mn}{(m-1)(h-n)}$
 D. $w = \frac{mn}{(n+1)(h-m)}$
38. The inverse of the sum of -3 and twice a certain number is $\frac{1}{5}$. Find the number.
- A. $1\frac{1}{2}$
 B. 1
 C. $1\frac{3}{5}$
 D. 4

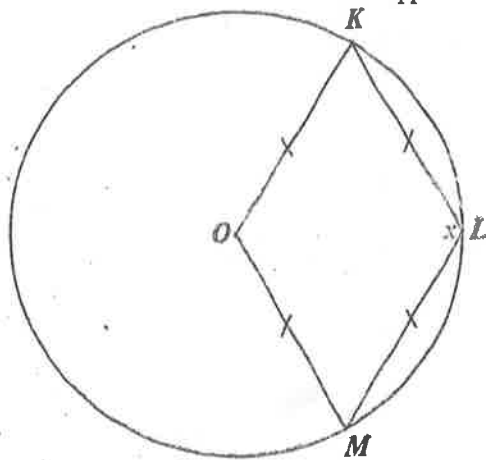

NOT DRAWN TO SCALE

In the diagram, O is the centre of the circle, $\angle KLM = x$ and $|OM| = |ML| = |LK| = |KO|$.
Find $\angle OKL$.

- A. 30°
- B. 15°
- C. 60°
- D. 120°

40.

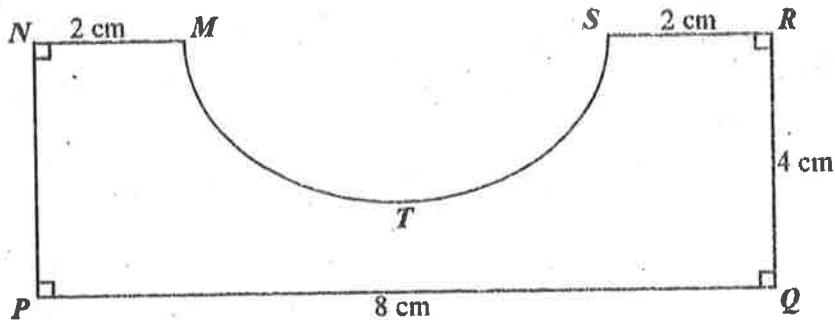

NOT DRAWN TO SCALE

The diagram shows a field $MNPQRST$, where MTS is a semicircle. Find the area of the field.

[Take $\pi = \frac{22}{7}$]

- A. 26.3 cm^2
- B. 25.7 cm^2
- C. 27.5 cm^2
- D. 28.6 cm^2

41. A box contains 12 red, 8 yellow and 10 green pebbles, all of the same size. If two pebbles are selected at random one after the other, **with replacement**, find the probability that the first is green and the second is **not** a red pebble.

- A. $\frac{1}{9}$
- B. $\frac{1}{5}$
- C. $\frac{15}{20}$
- D. $\frac{17}{20}$

47. A man cycles a distance of $(3a)$ km at V km/h and then walks a distance of a km at $(V - 7)$ km/h. Find the total number of hours he spent travelling.
- A. $\frac{V}{3a} + \frac{V-7}{a}$
- B. $\frac{3a}{V} + \frac{a}{V-7}$
- C. $\frac{4a}{2V-7}$
- D. $\frac{2V-7}{4a}$
48. Peter is in the East of Tom and Tom is in the North of John. If Mike is in the South of John, in which direction of Peter is Mike?
- A. South West
- B. South East
- C. South
- D. North East
49. Simplify: $\frac{25p^2 - q^2}{5p^2 + 6pq + q^2}$.
- A. $\frac{5p - q}{p + q}$
- B. $\frac{5p - q}{p - q}$
- C. $\frac{5p + q}{p + q}$
- D. $\frac{5p + q}{p - q}$
50. Correct, 5.40514 to three significant figures.
- A. 5.41
- B. 541
- C. 5.45
- D. 5.40

END OF PAPER

SC 402208
WASSCE 2025
GENERAL MATHEMATICS/
MATHEMATICS (CORE) 2 **2**
Essay
2½ hours

Name

Index Number

THE WEST AFRICAN EXAMINATIONS COUNCIL

**West African Senior School Certificate Examination
for School Candidates**

SC 2025

GENERAL MATHEMATICS/ MATHEMATICS (CORE) 2
ESSAY
[100 marks]

2½ hours

Write your name and index number in ink in the spaces provided above.

Answer ten questions in all. All the questions in Section A and five questions from Section B.

In each question, all necessary details of working, including rough work, must be shown with the answer.

Give answers as accurately as data and tables allow.

Graph papers are provided for your use in the examination.

The use of non-programmable, silent and cordless calculator is allowed.

2
SECTION A
[40 marks]

Answer all the questions in this section. All questions carry equal marks.

1. A distributing van supplies drinks between two Depots, Koti and Abam, covering the **first** half of the distance at an average speed of 60 km/h and the **second** half at 90 km/h. The total distance between the two depots is 300 km.
 - (a) Calculate, for the entire journey, the average speed of the van.
 - (b) If the speed of the van in the **first** half of the journey is reduced to 50 km/h, determine its effect on the overall time.

2. A businessman, invested some amount in two accounts which pay 11 % and 10 % simple interest annually. The amount invested at 11 % is 140 % of the amount invested at 10 %. After $3\frac{1}{2}$ years, he earned a total of GH¢ 22,580.60 as interest. How much was invested at 11 %?

3. Abudu builds a rainwater collection system in a shape of a hemispherical tank of radius 2 m to irrigate a 500 m^2 farm. Each square metre of the farm requires 50 litres of water. Determine, with a mathematical statement, if a full tank of water would be sufficient to irrigate the farm?
[Take $\pi = \frac{22}{7}$]

4. From the top of a lighthouse 100 m high, the angles of depression of two cargo ships are observed at 48° and 36° . The foot of the lighthouse and the sea level are on the same horizontal and the two ships are on the same side of the lighthouse.
 - (a) Illustrate the information in a diagram.
 - (b) Find, correct to the **nearest** metre, the distance between the two ships.

5. The midpoint of the line joining P(2x, 3) and H(-4, y) is M(1, 2x - 1). Find:
 - (a) the values of x and y;
 - (b) |PH|.

Answer five questions only from this section. All questions carry equal marks.

6. The estimated cost of building a basket ball court was \$64,000.00. It was made up of the cost of labour, materials and the contractor's charges in the ratio 12 : 15 : 5 respectively. At the start of the construction, the cost of labour increased by $s\%$, materials increased by $2s\%$ due to inflation but the contractor's charges remained same. After the increase, the cost of labour was **two-thirds** the cost of materials. Determine the:

- (a) value of s ;
(b) new cost of building the court.

7.

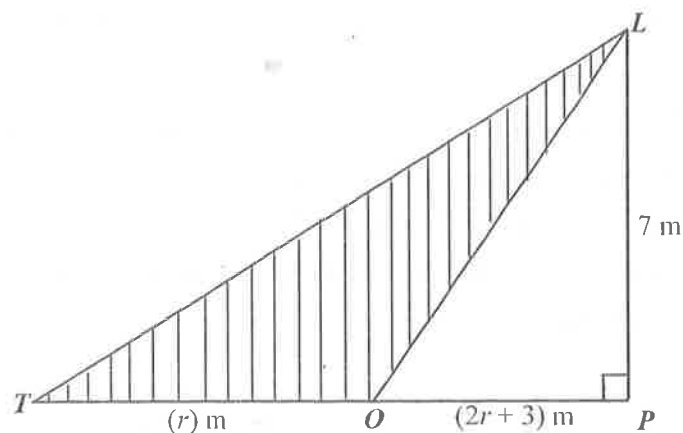

NOT DRAWN TO SCALE

The shaded region of the figure is a pattern to be produced in a steel casting shop. If the area of $\triangle PTL$ is 98 m^2 , calculate, correct to **one** decimal place, the:

- (a) value of r ;
(b) area of the pattern;
(c) perimeter of the pattern.
8. (a) Seidu planned to plough 120 acres of farmland each day. Due to unforeseen circumstances, 85 acres could be ploughed each day, resulting in an increase in the planned time by 2 days with 40 acres of the land still remained to be ploughed. Calculate the:
- (i) number of days Seidu planned to plough the land initially;
(ii) total area of the farmland.
- (b) Nkwanta is 5° N and another town, Aboabo is at 6.8° N on the earth's surface. Find, correct to the **nearest** whole number, the distance between the two towns.
[Take $\pi = \frac{22}{7}$, $R = 6,400 \text{ km}$]

9. A telecommunication mast and a pillar stand on the same horizontal level. From the midpoint, O , between the foot of the pillar, X , and the foot of the mast, Y , the angle of elevation of the top of the mast E , is 70° . From the point, O , the angle of elevation of the top of the pillar, P , is 28° . If the pillar is 10 m high:
- represent the information in a diagram;
 - calculate, correct to the **nearest** whole number:
 - the height of the mast;
 - $|PE|$.
10. (a) The points A , T and M lie on a circle with centre O . An angle subtended at the centre by the minor arc AT is 88° .
- Illustrate the information in a diagram.
 - If M is a point on the minor arc, determine the value of the angle subtended by the chord AT at M .
- (b) A painter, Fiifi, is able to paint 400 doors each day in 8 hours. Another painter, Joojo, paints at $\frac{3}{2}$ times Fiifi's rate when painting same kind of doors.
- How many doors can Joojo paint in 8 hours?
 - If **both** Fiifi and Joojo decide to work together, determine the time required to paint 2000 doors.
11. A playground is in the form of an isosceles triangle with vertices KLM .
 $|KL| = |KM| = (2u + v)$ m, $|LM| = (3u + 5)$ m and the perimeter of the playground is $(7v + 3)$ m.
- Illustrate the information in a diagram.
 - Given that $u : v = 2 : 3$, find, correct to **one** decimal place, the:
 - value of u and v ;
 - area of the playground.
12. The following are the marks obtained by 50 students in an Science test.
- | | | | | | | | | | |
|----|----|----|----|----|----|----|----|----|----|
| 27 | 31 | 35 | 52 | 81 | 50 | 48 | 15 | 59 | 6 |
| 17 | 41 | 30 | 94 | 23 | 38 | 40 | 70 | 76 | 18 |
| 52 | 61 | 43 | 68 | 56 | 57 | 62 | 82 | 54 | 25 |
| 18 | 35 | 9 | 74 | 59 | 46 | 71 | 4 | 74 | 33 |
| 61 | 16 | 50 | 45 | 41 | 45 | 28 | 22 | 26 | 45 |
- Using the class interval, 1 – 10, 11 – 20, 21 – 30, ... , construct a cumulative frequency table for the distribution.
 - Draw a cumulative frequency curve for the distribution.
 - Use the curve to find the upper quartile.
 - If **only** 10 % of the students passed the test, use the curve to determine the pass mark.

13. (a)

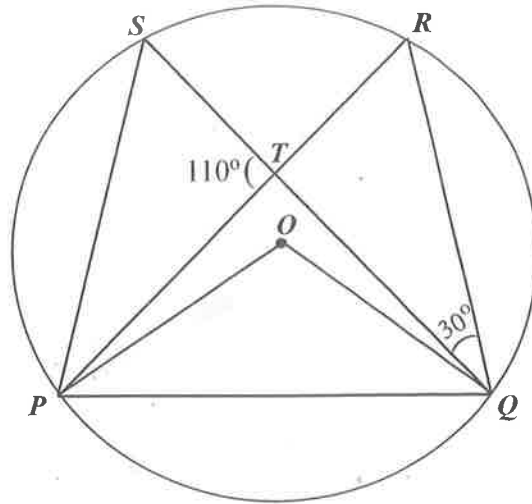
**NOT DRAWN TO SCALE**

In the diagram, P , Q , R and S lie on the circumference of the circle centre O . \overline{PR} and \overline{QS} intersect at T such that $\angle RQS = 30^\circ$ and $\angle STP = 110^\circ$. Calculate:

- (i) $\angle POQ$;
- (ii) $\angle TPS$.

(b) Consider the following statements.

f : Most Arts students are good at acting.

g : Some Non-Arts students are also good at acting.

- (i) Illustrate the information in a Venn diagram.
- (ii) Determine from the diagram whether the following conclusions are **Valid** or **Not Valid**.
 - (α) Alfred is a non-Arts student so he is **not** good at acting.
 - (β) Fafa is an Arts student so she is good at acting.

END OF PAPER